

TECHNICAL DATASHEET: YH128C7

Archivo	Revisión	Elaboro	Hoja
YH128C7_TDS	03/2023	RGE	1

TEST CONDITION AHRI-540-2020 HIGH TEMPERATURE/AIR CONDITINING/CHILLERS						REFRIGERANT	ELECTRIC SUPPLY	TOLERANCE
Units	Te	Tc	SH	SC	Tret.	R-22	208-230V /3PH/50-60Hz	± 10%
Imperial °F	45	130	20	15	65			

NOMINAL TEST CONDITION PARAMETERS	Value	Imperial	Value	International	Comments
Frigorific potency	52833	Btuh	15,494	Watt	
Instant energy consumption	5060	Watt	5,060	Watt	
Efficiency BTUh/W (EER) W/W (COP)	10.44	Btuh/W	3.06	W/W	
Nominal current consumption	16.3	A	16.3	A	
Nominal Displacement	2.83	In/Rev	46.4	Cm ² /Rev.	
Total heat rejection	70,088	Btuh	19,146	Watt	

Mechanical data	
Displacement at 3500 RPM	6.11 CFM
Commercial Horsepower	4.3HP
Compressor Weight	31 kg (68.2 Lb.)
3GS Oil original charge	1.4 L (49 Oz.)
3GS oil refilling charge	1.25 L (44 Oz.)
Center holes mounting	7.5 x 7.5 in
Required food print	9.5 x 9.5 in
Total height	418mm 16.5 in
Ø Discharge tube	½"
Ø Suction Tube	7/8"

Electrical data	
Max braker protection	15.5A
Locked Rotor Amp. LRA	99A
Voltage range	208 – 230 V AC
Phases	1
Electric supply frequency	50 - 60 HZ
VFD app range	30 - 70 Hz
Run capacitor	
Start capacitor	None
Start relay	None
Crankcase heater	70 W

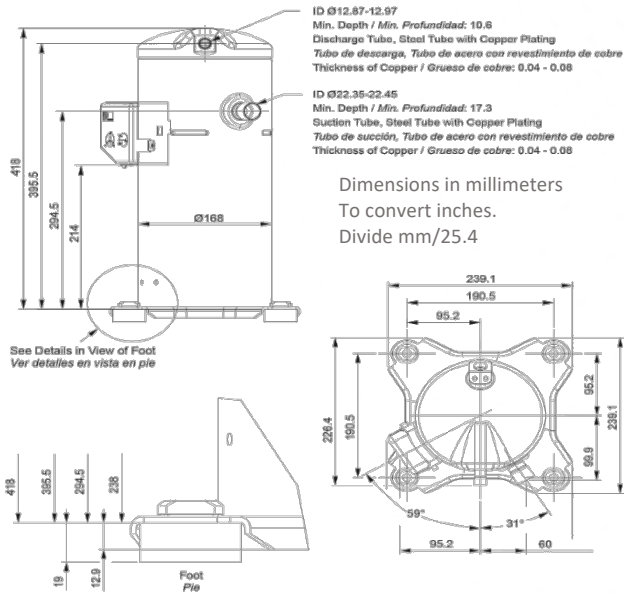

Frigorific potency in Btuh performance at different conditions in °F								
↓Tc Te→	-13	0	10	20	30	40	50	54
77	20901	29439	36850	45388	55497	67484	81794	88248
80	20286	28790	36098	44500	54438	66186	80257	86609
90	18476	26809	33844	41836	51194	62259	75510	81486
100	16734	24965	31761	39411	48256	58673	71138	76739
110		23087	29712	36986	45388	55223	66938	72231
120			27390	34425	42382	51672	62703	67689
130				31454	39070	47881	58263	62942

Current consumption in Ampere								
-13	0	10	20	30	40	50	54	
10.72	10.73	10.66	10.61	10.63	10.78	11.12	11.33	
10.91	10.88	10.77	10.67	10.63	10.72	10.99	11.16	
11.77	11.66	11.47	11.25	11.06	10.97	11.04	11.12	
12.88	12.77	12.55	12.28	12.01	11.82	11.75	11.77	
	14.06	13.88	13.62	13.34	13.1	12.96	12.94	
		15.29	15.11	14.88	14.66	14.52	14.49	
			16.6	16.48	16.35	16.27	16.26	

Instantaneous potency in W performance at different conditions in °F								
↓Tc Te→	-13	0	10	20	30	40	50	54
77	2619	2601	2585	2577	2585	2616	2679	2715
80	2748	2723	2702	2689	2690	2715	2772	2805
90	3185	3141	3104	3073	3056	3060	3095	3119
100	3655	3595	3543	3496	3461	3447	3462	3478
110		4104	4040	3979	3928	3898	3894	3902
120			4619	4545	4481	4435	4415	4417
130				5216	5141	5081	5047	5042

Mass flow in Lb/h								
-13	0	10	20	30	40	50	54	
109.89	155.8	192.35	233.35	282.09	341.55	415.11	449.1	
107.31	153.27	189.61	230.16	278.22	336.78	409.2	442.67	
101.46	148.32	184.47	224.08	270.43	326.52	395.7	427.67	
97.61	146.47	183.28	222.77	268.25	322.71	389.49	420.28	
	144.89	183.18	223.4	268.85	322.51	387.74	417.69	
		181.34	223.13	269.39	323.09	387.6	417.05	
			219.12	267.02	321.6	386.23	415.51	