

TECHNICAL DATASHEET: YH266C1

Archivo	Revisión	Elaboro	Hoja
YH266C1_TDS	03/2023	RGE	1

TEST CONDITION AHRI-540-2020 HIGH TEMPERATURE/AIR CONDITINING/CHILLERS						R-410A	460V /3PH/50-60Hz	TOLERANCE ± 10%
Units	Te	Tc	SH	SC	Tret.			
Imperial °F	45	130	20	15	65			

NOMINAL TEST CONDITION PARAMETERS	Value	Imperial	Value	International	Comments
Frigorific potency	110140	Btuh	27,952	Watt	
Instant energy consumption	10117	Watt	8758	Watt	
Efficiency BTUh/W (EER) W/W (COP)	10.88	Btuh/W	3.09	W/W	
Nominal current consumption	15.55	A	13.44	A	
Nominal Displacement	0.00	In/Rev	100.0	Cm³/Rev.	
Total heat rejection	125,183	Btuh	24,151	Watt	

Mechanical data	
Displacement at 3500 RPM	4.76 CFM
Commercial Horsepower	9HP
Compressor Weight	33 kg (72.6 Lb.)
POE Oil original charge	1.4 L (49 Oz.)
POE oil refilling charge	1.25 L (44 Oz.)
Center holes mounting	7.5 x 7.5 in
Required food print	9.5 x 9.5 in
Total height	16.5 in
Ø Discharge tube	½"
Ø Suction Tube	7/8"

Electrical data	
Braker protection MOC	10 A.
Locked Rotor Amp. LRA	45 A.
Voltage range	460 VAC
Phases	3
Electric supply frequency	50 - 60 HZ
VFD app range	35 - 65 Hz
Run capacitor	None
Start capacitor	None
Start relay	None
Crankcase heater	70 W

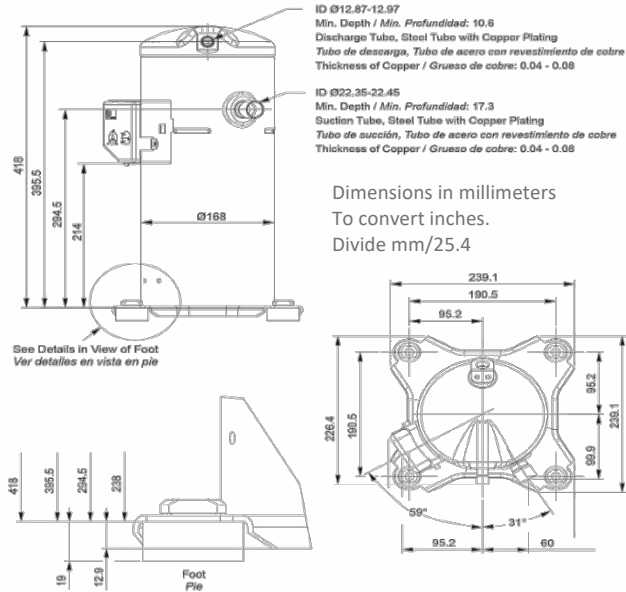

Frigorific potency in Btuh performance at different conditions in °F								
↓ Tc Te →	-13	0	10	20	30	40	50	54
77	43544	61371	76807	94600	115638	140637	170486	183907
80	42314	60005	75236	92756	113418	137973	167275	180492
90	38523	55872	70558	87190	106690	129777	157371	169803
100	34869	52047	66220	82101	100543	122298	148219	159933
110		48086	61883	77115	94566	115092	139510	150507
120			57102	71719	88351	107715	130699	141047
130				65571	81452	99757	121410	131143

Instantaneous potency in W performance at different conditions in °F								
↓ Tc Te →	-13	0	10	20	30	40	50	54
77	5236	5199	5168	5152	5168	5230	5357	5429
80	5493	5444	5403	5375	5379	5428	5541	5607
90	6367	6280	6206	6144	6109	6118	6187	6235
100	7307	7187	7083	6989	6920	6892	6921	6952
110		8205	8076	7954	7854	7792	7785	7801
120			9234	9087	8959	8868	8827	8830

Current consumption in Ampere								
-13	0	10	20	30	40	50	54	
10.23	10.23	10.17	10.12	10.14	10.28	10.61	10.8	
10.41	10.37	10.28	10.18	10.14	10.22	10.48	10.64	
11.23	11.12	10.94	10.73	10.55	10.46	10.53	10.61	
12.28	12.18	11.97	11.71	11.46	11.27	11.21	11.23	
	13.41	13.24	12.99	12.72	12.49	12.36	12.34	
		14.59	14.41	14.19	13.98	13.84	13.82	
			15.83	15.72	15.6	15.52	15.51	

Mass flow in Lb/h								
-13	0	10	20	30	40	50	54	
10429	10277	10159	10090	10079	10429	10277	10159	
10429	10277	10159	10090	10079	10429	10277	10159	
10429	10277	10159	10090	10079	10429	10277	10159	
203.44	305.27	381.98	464.29	559.08	672.57	811.76	875.93	
	301.96	381.78	465.61	560.33	672.17	808.11	870.54	
		377.95	465.05	561.45	673.38	807.81	869.2	