

Basic Specification	
Model	YM200E7G-100 (Including Extended Models)
Type	Low Side Shell Design Scroll Compressor
Application	Medium Temp. Refrigeration
Power	12 HP
Capacity (BTU/Hr)	82399
Refrigerant	R448A/R449A
Displacement(cc/rev)	189.1
Cooling Capacity(W) ^(a)	24150
Input Power(W) ^(a)	10882
RLA(A) ^(a)	36.1
Cooling COP(W/W) ^(a)	2.22
Power Supply	208-230V/3~/60Hz
Min. Operating Voltage(V)	187
Max. Operating Voltage(V)	253
LRA(A)	290
Max. Operating Current(A) ^(b)	53.3
Rated Speed(r/min) ^(a)	3500
Compressor Weight (With Oil)(kg)	54
Oil Type	POE
Oil Kinematic Viscosity (cSt, 40°C)	32
Oil Density (kg/L, 20°C)	0.977
Primary Charge(L)	2.7
Recharge(L)	2.55
Oil Circulation Rate ^(a)	≤1%
Rated Sound (Sound Power)(dBA) ^(c)	79
Max. Operating Sound in Running Envelope (Sound Power)(dBA)	84
Vibration Displacement Peak-Peak (mm) ^(d)	≤0.12
Moisture (mg)	≤1500
Impurity (mg)	≤180
LVS(V) ^(e)	177
MOV (V) ^(f)	187
Start Capacitor (μF/V)	/
Start Relay	/
Run Capacitor (μF/V)	/
IP Class of Terminal Box	IP54
Compressor Color	Black

Motor Parameters	
Motor Type	Three-phase asynchronous motor
Motor Pole	2
Motor Insulation Class(°C)	130(B Class)
Line to Line Resistance UV(CS)(Ω, 25°C)	0.258(± 10%)
Line to Line Resistance UW(CR)(Ω, 25°C)	0.258(± 10%)
Line to Line Resistance VW(SR)(Ω, 25°C)	0.258(± 10%)
Dielectric Strength	2000VAC / 1s / 60Hz, Leakage Current≤5mA
Insulation Resistance(MΩ)	≥20
Ground Resistance(Ω)	≤0.1

Safety Operating Limit	
Tightness Test Pressure (MPa)	3.8-4.0
Max. Operating Pressure	
High Side(MPa) Low Side(MPa)	H3.2/L2.0
Compressor FreeSpace(Without Oil)	
High Side(L) Low Side(L)	H0.9/L6.3
Max. Refrigerant Charge(kg)	See Notes
Discharge Temperature Limit(°C)	≤125 (120mm to compressor discharge connection and well insulated)
Start-Stop Interval	See Notes

Performance Condition:

Condition	Condition Description
a	Rated Condition
b	Max. Load Condition, 90% Rated Voltage
c	Rated Condition, A Weighted Sound Power
d	Rated Condition, Max Operating Normal Displacement of Compressor Housing
e	Discharge Pressure and Suction Pressure: Saturated Refrigerant Pressure at 40°C
f	Max. Load Condition

2. Rated Condition, 48 Hours Break-in-Running before implementing Performance and Sound Testing

Item	Rated Condition	Max. Load Condition
E.T.(°C)/C.T.(°C)/S.H.(K)/ S.C.(K)/A.T.(°C)	-6.7/48.9/11.1/0/35	10/65/11.9/0/46.1
Cooling Capacity Deviation	≥92.5%	-
Power Deviation	≤107.5%	-
COP Deviation	≥92.5%	-

3. Internal Protector

Protection Method	Config	Parameter		
Internal Overload Protector	With	Vendor	Vendor 1	Vendor 2
		Model	UP9NY0506-XX	
		Open Temp.(°C)	135±5	
		Close Temp. (°C)	60±9	
		Short Time Trip	174A 3-10s	A S
Internal Pressure Relieve Valve	With	2.76-3.10MPa		

4. Accessory

Item	Name	P.N.	PCS
1	Grommet	070-0003-00	4
2	Sleeve	010-0014-00	4

5. Compressor Operating Envelope

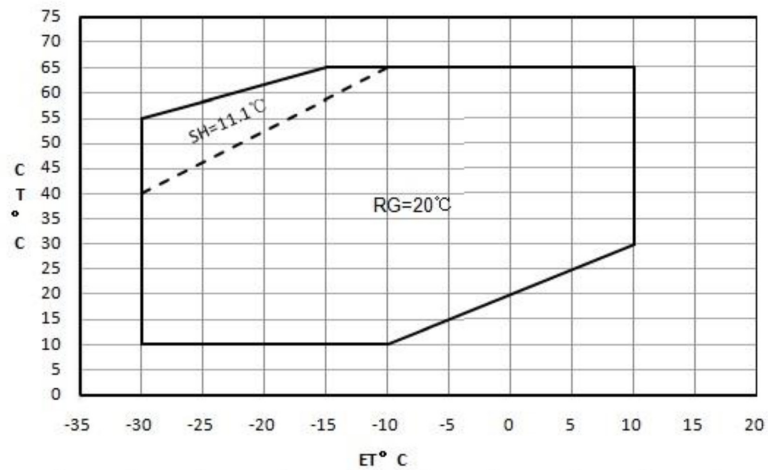

Compressor Performance Sheet

- » Performance Based on Superheat is within the Operating Envelope, Subcooling after Condenser is 0K;
- » Performance Calculated by Coefficients of Polynomial is Only Suitable for the Condition within Operating Envelope
- » Capacity, Power can be Calculated by Coefficients of Polynomial

		Performance Table								
Item	E.T. (°C)	-30	-25	-20	-15	-10	-5	0	5	10
Cooling Cap. (W)	65					16483	19928	24018	28762	34173
	60				14876	18066	21923	26458	31685	37613
	55			13210	16054	19589	23827	28780	34458	40874
	50		11672	14082	17206	21057	25646	30986	37086	43960
	45	10453	12338	14963	18338	22475	27386	33082	39575	46876
	40	11013	13049	15858	19454	23847	29049	35072	41928	49627
	35	11653	13808	16773	20559	25178	30642	36962	44151	52218
	30	12376	14621	17711	21658	26474	32170	38757	46248	54654
	25	13188	15493	18678	22756	27738	33636	40461	48224	
	20	14093	16428	19679	23858	28977	35046	42078		
10	16202	18507	21800	26092	31394					
Power (W)	65					13561	14284	14932	15556	16205
	60				11835	12565	13187	13751	14307	14904
	55			10223	10993	11621	12159	12654	13158	13720
	50		8675	9519	10187	10731	11199	11643	12111	12653
	45	7145	8096	8837	9421	9895	10311	10719	11167	11706
	40	6675	7524	8180	8694	9116	9495	9883	10328	10880
	35	6198	6961	7548	8009	8394	8753	9137	9594	10176
	30	5716	6408	6942	7366	7731	8087	8482	8969	9595
	25	5229	5868	6365	6768	7129	7496	7921	8452	
	20	4739	5341	5817	6216	6588	6984	7453		
10	3758	4334	4816	5254	5699					

Ten Coefficients of Polynomial			
Expression	$z = p_0 + p_1 \cdot x + p_2 \cdot y + p_3 \cdot x^2 + p_4 \cdot x \cdot y + p_5 \cdot y^2 + p_6 \cdot x^3 + p_7 \cdot x^2 \cdot y + p_8 \cdot x \cdot y^2 + p_9 \cdot y^3$		
Description	z: Cooling Capacity (W) or Power (W) Specially: Heating Capacity (W) = Cooling Capacity (W) + Power (W) x: E.T. °C y: C.T. °C p0~p9: Coefficients of Polynomial		
Cooling Cap. Factor	Value	Power Factor	Value
p0	47786.214247	p0	6553.580288
p1	1623.91576	p1	179.083779
p2	-258.083082	p2	5.19904
p3	22.324369	p3	3.777673
p4	-3.630338	p4	-5.021994
p5	-1.23637	p5	2.027101
p6	0.015505	p6	0.066575
p7	-0.141892	p7	-0.065649
p8	-0.119522	p8	0.064592
p9	-0.006444	p9	-0.001908

Notes: Coefficients of polynomial are based on the fitting results of some sample data, which can be used as a reference of compressor selection, but cannot completely eliminate customer's test.

Grommet Drawing

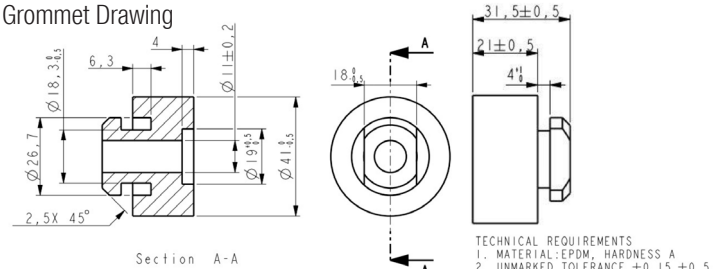

Sleeve Drawing

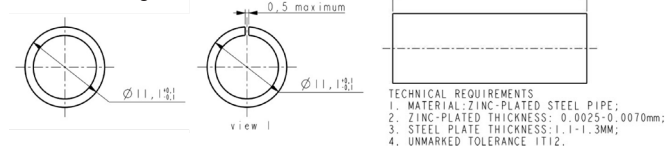

T-Box Layout Standard

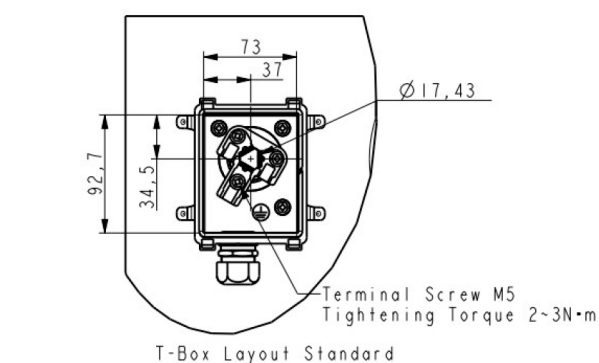

Notes

- » It is not allowed to perform vacuum in the system by using the refrigeration compressor. The compressor can start only after the refrigerant charged. In some cases, such as on the field site, if it is limited by the situation that can't charge the required volume of refrigerant, 50% of the required refrigerant is charged necessary before the compressor starts. Double check the system and make sure everything is under safe status, then power on the compressor and charge the remained refrigerant when the compressor is running.
- » It is not allowed to charge the refrigerant from the suction or discharge line closes to the compressor. The charge port should be arranged on the connection pipe of suction line accumulator or receiver, which is on the side far away to the compressor, to avoid the liquid refrigerant flood back.
- » Refrigerant charge limitation: the ratio between the weight of oil and refrigerant should be >=0.4.
- » It is not allowed to vacuum by compressor, not allowed to run the compressor without refrigerant, and not allowed to run the compressor on the reversed direction for long duration.
- » The compressor can only work with approved refrigerant.
- » The compressor is not allowed to work outside its envelope, the system should guarantee the suction line superheat and avoid the liquid refrigerant flood back.
- » When the suction and discharge plugs are removed, the assembly and brazing should be done in 15 minutes.
- » The frequently start/stop should be avoided. The suggested minimum continuous running time is 10 minutes to guarantee the safe oil level (>=50% initial charge volume), the suggested minimum interval duration between start and stop is 3 minutes.
- » The deviation of supplied voltage should be less than +/-10% of rated voltage.
- » A 90W crankcase heater is recommended to avoid the refrigerant migration during the off circle and flood start. The crankcase heater should be power on 12 hours earlier than the first start or restart after long duration off.
- » The system should be equipped with necessary protection devices, such as pressure, temperature, oil return, overcurrent and phase fault, etc.
- » The compressor is not allowed to lay down or place upside down during transportation, stock and installation. The maximum inclination is 15° when the compressor is running.

Drawings

Outline Drawing

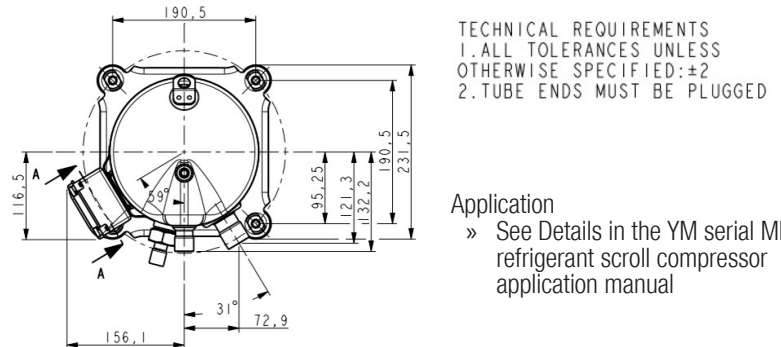
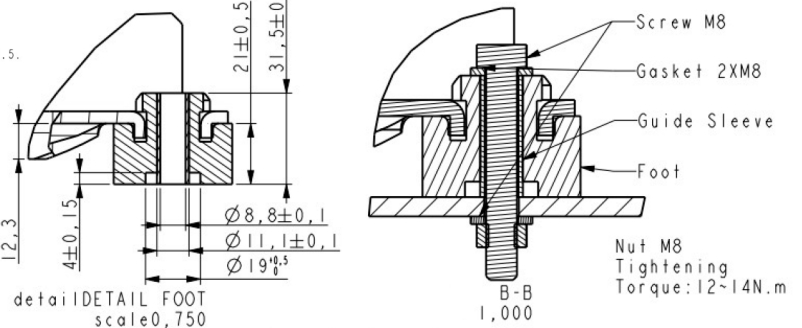
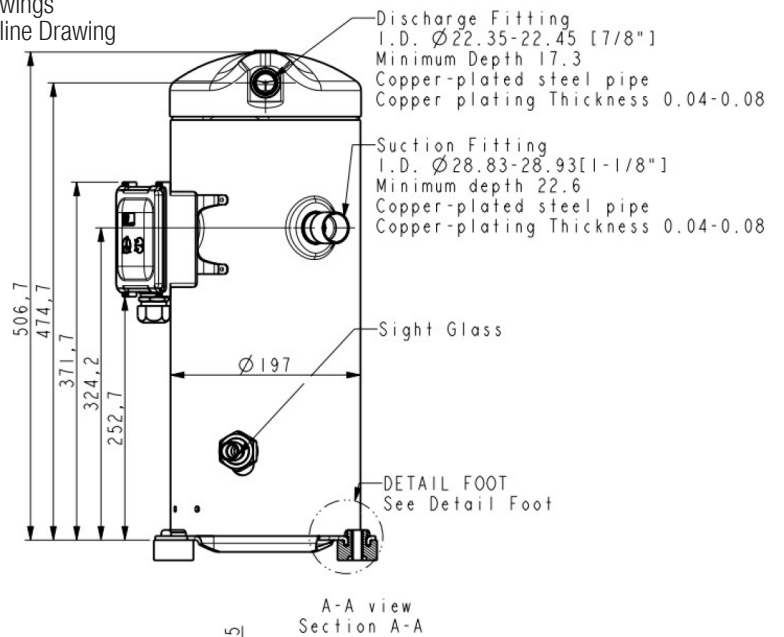

Application

- » See Details in the YM serial MBP refrigerant scroll compressor application manual