

Basic Specification	
Model	YM410E1S-100
Type	Low Side Shell Design Scroll Compressor
Application	Medium temperature ref.
Power	25 HP
Capacity (BTU/Hr)	163000
Refrigerant	R-404A
Displacement(cc/rev)	392.0
Cooling Capacity(W) ^(a)	47040
Input Power(W) ^(a)	23280
RLA(A) ^(a)	34.5
Cooling COP(W/W) ^(a)	2.02
Power Supply	380-420V/3~/50Hz or 460V/3~/60Hz
Min. Operating Voltage(V)	414
Max. Operating Voltage(V)	506
LRA(A)	266.0
Max. Operating Current(A) ^(b)	55.0
Rated Speed(r/min) ^(a)	3500
Compressor Weight (With Oil)(kg)	104
Oil Type	POE
Oil Kinematic Viscosity(cSt, 40°C)	32
Oil Density(kg/L, 20°C)	0.977
Primary Charge(L)	5.5
Recharge(L)	5.3
Oil Circulation Rate ^(a)	≤1%
Rated Sound(Sound Power)(dBA) ^(c)	84
Max. Operating Sound in Running Envelope (Sound Power)(dBA)	91
Vibration Displacement Peak-Peak(mm) ^(d)	≤0.12
Moisture(mg)	≤1500
Impurity(mg)	≤180
LVSV(V) ^(e)	391
MOV (V) ^(f)	414
Start Capacitor(μF/V)	/
Start Relay	/
Run Capacitor(μF/V)	/
IP Class of Terminal Box	IP54
Compressor Color	Black

Motor Parameters	
Motor Type	Three-phase asynchronous motor
Motor Pole	2
Motor Insulation Class(°C)	130 (B Class)
Line to Line Resistance UV(CS)(Ω, 25°C)	0.46 (± 10%)
Line to Line Resistance UW(CR)(Ω, 25°C)	0.46 (± 10%)
Line to Line Resistance VW(SR)(Ω, 25°C)	0.46 (± 10%)
Dielectric Strength	2000VAC / 1s / 50Hz or 60Hz, Leakage Current ≤5mA
Insulation Resistance(MΩ)	≥20
Ground Resistance(Ω)	≤0.1

Safety Operating Limit	
Tightness Test Pressure (MPa)	3.8-4.0
Max. Operating Pressure	
High Side(MPa) Low Side(MPa)	H3.2/L2.0
Compressor FreeSpace (Without Oil)	
High Side(L) Low Side(L)	H1.75/L14.7
Max. Refrigerant Charge(kg)	See Notes
Discharge Temperature Limit(°C)	≤125 (120mm to compressor discharge connection and well insulated)
Start-Stop Interval	See Notes

Performance Condition:

Condition	Condition Description
a	Rated Condition
b	Max. Load Condition, 90% Rated Voltage
c	Rated Condition, A Weighted Sound Power
d	Rated Condition, Max Operating Normal Displacement of Compressor Housing
e	Discharge Pressure and Suction Pressure: Saturated Refrigerant Pressure at 40°C
f	Max. Load Condition

2. Rated Condition, 48 Hours Break-in-Running before implementing Performance and Sound Testing

Item	Rated Condition	Max. Load Condition
E.T.(°C)/C.T.(°C)/S.H.(K)/ S.C.(K)/A.T.(°C)	-6.7/48.9/11.1/0/35	10/65/11.9/8.3/46.1
Cooling Capacity Deviation	≥95.0%	/
Power Deviation	≤105.0%	/
COP Deviation	≥95.0%	/

3. Internal Protector

Protection Method	Config	Parameter		
External Overload Protector	With	Model	INT69-E1	SE-E1
		Open Temp.(°C)	150±5	150±5
		Supply Voltage(V)	115-230	208-240
		Reset Method	Restart after power off	Restart after power off
Internal Pressure Relieve Valve	With	2.76-3.10MPa		

4. Accessory

Item	Name	P.N.	PCS
1	Grommet	070-3033-00	4
2	Sleeve	010-3033-00	4
3	Grommet Screw Grommet Nut	GB/T5783-2000	4
		GB/T6170-2000	4
4	Grommet Washer	GB/T96.1 10	8

5. Compressor Operating Envelope

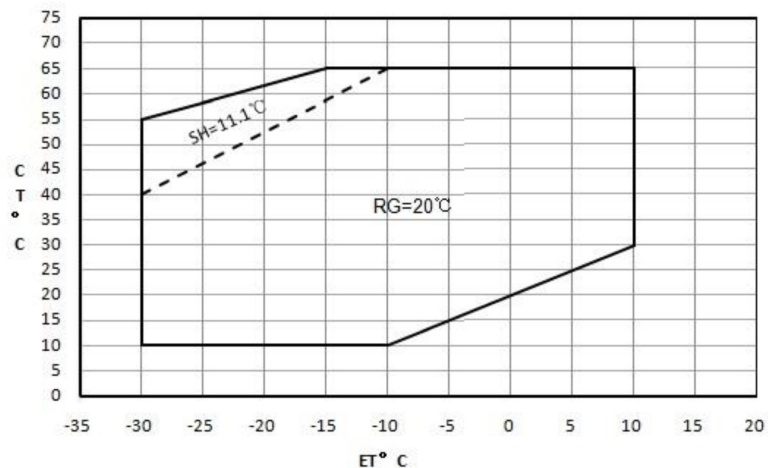

Compressor Performance Sheet

- » Performance Based on Superheat is within the Operating Envelope, Subcooling after Condenser is OK;
- » Performance Calculated by Coefficients of Polynomial is Only Suitable for the Condition within Operating Envelope
- » Capacity, Power can be Calculated by Coefficients of Polynomial

Performance Table										
Item	E.T. (°C)	-30	-25	-20	-15	-10	-5	0	5	10
Cooling Cap. (W)	65				30002	35615	42559	51144	61681	74482
	60			27804	33416	40162	48352	58299	70314	84707
	55	19870	24839	30433	36964	44744	54084	65295	78689	94578
	50	21334	26894	33195	40548	49265	59657	72036	86712	103998
	45	23032	29086	35996	44073	53630	64976	78424	94285	112871
	40	24866	31317	38739	47443	57742	69945	84365	101313	121101
	35	26741	33491	41327	50561	61504	74467	89762	107700	128592
	30	28561	35513	43666	53332	64822	78447	94519	113349	135248
	25	30230	37286	45658	55658	67598	81787	98539	118164	
	20	31651	38714	47208	57445	69736	84393	101727		
Power (W)	65				26795	28545	30179	31702	33123	34449
	60			23165	24895	26508	28009	29408	30711	31926
	55	18081	19912	21616	23203	24678	26049	27324	28511	29616
	50	17003	18677	20232	21675	23014	24257	25409	26481	27477
	45	16046	17564	18970	20272	21476	22590	23622	24579	25469
	40	15167	16531	17790	18951	20021	21009	21921	22765	23549
	35	14326	15537	16649	17671	18609	19471	20265	20998	21676
	30	13480	14539	15507	16390	17197	17935	18612	19234	19809
	25	12589	13497	14321	15068	15745	16360	16920	17433	
	20	11611	12370	13051	13662	14211	14704	15149		
15	10504	11115	11655	12132	12553	12925				
10	9227	9691	10091	10435	10730					

Notes

- » It is not allowed to perform vacuum in the system by using the refrigeration compressor. The compressor can start only after the refrigerant charged. In some cases, such as on the field site, if it is limited by the situation that can't charge the required volume of refrigerant, 50% of the required refrigerant is charged necessary before the compressor starts. Double check the system and make sure everything is under safe status, then power on the compressor and charge the remained refrigerant when the compressor is running.
- » It is not allowed to charge the refrigerant from the suction or discharge line closes to the compressor. The charge port should be arranged on the connection pipe of suction line accumulator or receiver, which is on the side far away to the compressor, to avoid the liquid refrigerant flood back..
- » Refrigerant charge limitation: the ratio between the weight of oil and refrigerant should be >=0.4.
- » It is not allowed to vacuum by compressor, not allowed to run the compressor without refrigerant, and not allowed to run the compressor on the reversed direction for long duration.
- » The compressor can only work with approved refrigerant.
- » The compressor is not allowed to work outside its envelope, the system should guarantee the suction line superheat and avoid the liquid refrigerant flood back.
- » When the suction and discharge plugs are removed, the assembly and brazing should be done in 15 minutes.
- » The frequently start/stop should be avoided. The suggested minimum continuous running time is 10 minutes to guarantee the safe oil level (>=50% initial charge volume), the suggested minimum interval duration between start and stop is 3 minutes.
- » Before startup, Discharge pressure-Suction pressure ≤0.3Mpa.
- » The deviation of supplied voltage should be less than +/-10% of rated voltage.
- » A 120W crankcase heater is recommended to avoid the refrigerant migration during the off circle and flood start. The crankcase heater should be power on 12 hours earlier than the first start or restart after long duration off.
- » The system should be equipped with necessary protection devices, such as pressure, temperature, oil return, overcurrent and phase fault, etc.
- » The compressor is not allowed to lay down or place upside down during transportation, stock and installation. The maximum inclination is 15° when the compressor is running.

Ten Coefficients of Polynomial			
Expression	$z = p_0 + p_1*x + p_2*y + p_3*x^2 + p_4*x*y + p_5*y^2 + p_6*x^3 + p_7*x^2*y + p_8*x*y^2 + p_9*y^3$		
Description	z: Cooling Capacity(W) or Power (W) Specially: Heating Capacity(W) = Cooling Capacity (W) + Power (W) x: E.T. °C y: C.T. °C p0~p9: Coefficients of Polynomial		
Cooling	Value	Power Factor	Value
p0	104229.4	p0	6439.324
p1	4071.868	p1	-1.86101
p2	348.8815	p2	528.175
p3	68.97017	p3	-0.25526
p4	-8.03534	p4	4.2345
p5	-26.2651	p5	-5.73893
p6	0.41516	p6	0.00991
p7	-0.46027	p7	-0.02764
p8	-0.39	p8	0.00492
p9	0.1282	p9	0.05527

Notes: Coefficients of polynomial are based on the fitting results of some sample data, which can be used as a reference of compressor selection, but cannot completely eliminate customer's test.

Grommet Drawing

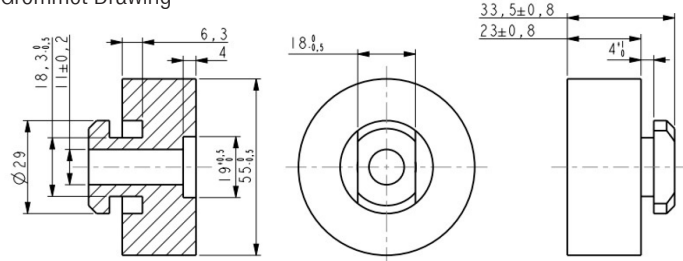

Sleeve Drawing

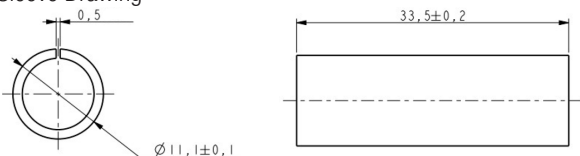

Wiring Connection

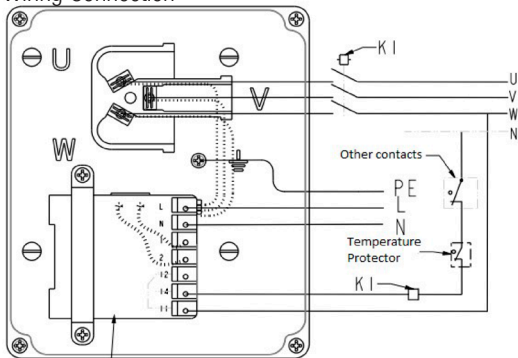

Notes: The dotted line in the figure is the wire that has been connected before leaving the factory, and the solid line is the wire that needs to be connected by the customer

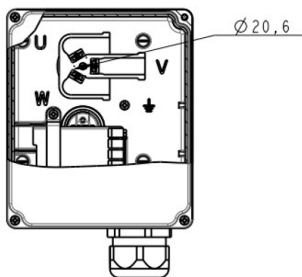

wiring connection

Application

- » See Details in the YM serial MBP refrigerant scroll compressor application manual

Drawings

Outline Drawing

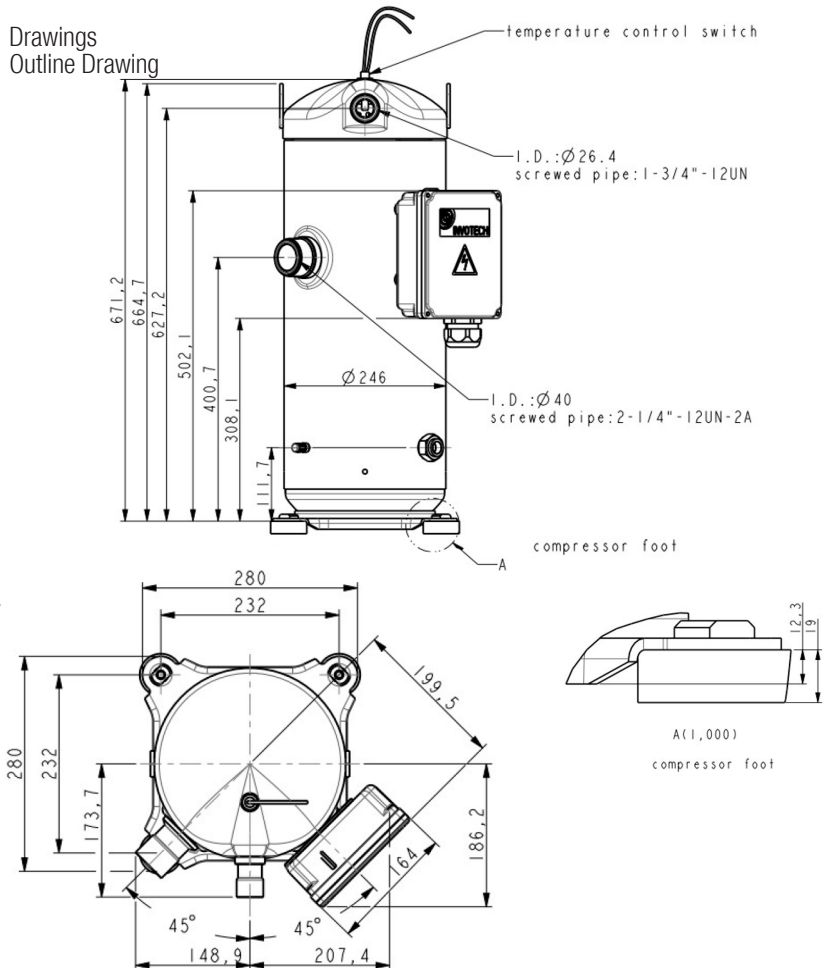

How to install

